

Lubricants and Fluids

LUBRICANTS AND FLUIDS

Recommendations for all climates and conditions.

Note: *Recommended oils are complete in themselves and additives should not be used.*

Note: *It is essential to change oil much more frequently if the vehicle is operated under severe conditions, especially if deep wading is carried out.*

Engine oil - V8 Petrol vehicles

Use a 5W/30 oil meeting specification ACEA: A1 or A3 (with API SJ, SL or SM).

Land Rover WSS-M2C913-B preferred.

Engine oil - V8 Petrol supercharged vehicles

Use a 5W/30 oil meeting specification ACEA: A1 or A3 (with API SJ, SL or SM).

Land Rover WSS-M2C913-B preferred.

Engine oil - Diesel vehicles

Use a 5W/30, 5W/40, 10W/30 or 10W/40 oil meeting specification ACEA: A3 and B3, and having a viscosity band recommended for the temperature range of your locality.

Engine oil temperature ranges

5W/30 will protect from -30°C to 35°C (-22°F to 95°F)

5W/40 will protect from -30°C to 50°C (-22°F to 122°F)

10W/30 will protect from -10°C to 35°C (-14°F to 95°F)

10W/40 will protect from -10°C to 50°C (-14°F to 122°F)

Main gearbox

Petrol: Shell ATF M1375.4

Diesel: Filled for life

Transfer gearbox

Petrol vehicles: Shell TF 0753.

Diesel vehicles: Castrol BOT 26 FMB1

Front and rear differentials

All vehicles: SAF XO.

Power steering

Texaco Cold Climate PAS fluid 14315.

Brake reservoir

Use Shell DOT4 ESL or a low viscosity DOT4 brake fluid that meets ISO 4925 class 6 and Land Rover LRES22BF03.

Windscreen washers

Screen washer fluid.

Engine cooling system

Petrol: Use Castrol Antifreeze SF, with one part antifreeze to one part water for protection down to -40°C (-40°F).

Diesel: Use Castrol Antifreeze NF, with one part antifreeze to one part water for protection down to -40°C (-40°F).

Capacities

CAPACITIES

The following capacities are approximate and provided as a guide only. All oil levels must be checked using the dipstick or level plugs as applicable.

Fuel tank	104.5 litres (23 gallons)
Engine oil refill and filter change: - Diesel vehicles - V8 NA Petrol vehicles - V8 SC Petrol vehicles	8.75 litres (15.4 pints) 7.7 litres (13.5 pints) 7.7 litres (13.5 pints)
Front differential	0.8 litres (1.4 pints)
Rear differential	1.2 litres (2.1 pints)
Washer reservoir	5 litres (8.8 pints)
Cooling system (refill): - Diesel vehicles - V8 NA Petrol vehicles - V8 SC Petrol vehicles	11 litres (19.36 pints) 9.5 litres (16.7 pints) 12 litres (21.1 pints)

Engines

ENGINES

Diesel

Recommended fuel	Diesel or Automotive Gas Oil (AGO) to EN 590 specification only. This engine is NOT COMPATIBLE with Bio-diesel fuel.
Capacity	2 926 cm ³
Firing order	1-5-3-6-2-4
Bore	84.0 mm
Stroke	88.0 mm
Number of cylinders	6
Compression ratio	18:1

V8 Petrol

Recommended fuel	UNLEADED 95 RON to EN 228 specification Unleaded with a RON no lower than 90 may be used
Capacity: - Normally aspirated - Supercharged	4 398 cm ³ 4 197 cm ³
Firing order	1-5-4-2-6-3-7-8
Bore: - Normally aspirated - Supercharged	88.0 mm 86.0 mm
Stroke	90.3 mm
Number of cylinders	8
Compression ratio: - Normally aspirated - Supercharged	10.5:1 9.1:1
Spark plugs	NGK IFR5N10
Spark plug gap	Non-adjustable

Wheels and Tyres

WHEELS AND TYRES

Wheel size and tyre specification

Wheel size	Tyre
7.5J x 18	255/60 R18 112 H or V- All terrain tyre
8J x 18	235/65 R18 110 H - Winter tread tyre
8J x 18	235/65 R18 110 H
8J x 18	255/60 R18 112 H or V
5.5J x 19	T175/80 R19 122M - (Temporary spare tyre)
8J x 19	255/55 R19 111 H or V- All terrain tyre
8.5J x 20	255/50 R20 109 Y- All terrain and all terrain sport tyre

Accessory wheels and tyres - insert details

Wheel size	Tyre	Tyre pressure	
		Front	Rear

Note: Accessory fit off-road tyres (with a speed rating of Q or T) are subject to speed restrictions. Q-rated tyres should not be used at speeds greater than 160 km/h (100 mph), T-rated tyres should not be used at speeds greater than 190 km/h (118 mph).

Tyre pressures

Tyre pressures are listed on a label on the B pillar on the driver's side (visible with the driver's door open). See **Tyre information label, 213**.

Temporary spare tyre pressure	kPa	bar	lbf/in ²
Any position or load condition	420	4.2	60

Weights

WEIGHTS

Approximate EEC kerb weights (full fuel tank):	
- Petrol engine vehicles	2 440 - 2 570 kg (5 379 - 5 666 lb)
- Diesel engine vehicles	2 435 - 2 570 kg (5 368 - 5 666 lb)
Maximum Gross Vehicle Weight (GVW)	3 050 kg (6 724 lb)
Maximum front axle load	1 530 kg (3 373 lb)
Maximum rear axle load	1 850 kg (4 078 lb)
Maximum roof rack load	100 kg (220 lb)

Note: Axle weights are non-additive; i.e. maximum GVW is not calculated by adding together maximum front and rear axle loads. The above individual maximum axle weights and gross vehicle weight must not be exceeded, except when towing.

Note: The weight of Land Rover approved roof bars and cross rail roof rack is allowed for before further weight calculations are made. However, if an alternative roof rack system is to be used, the weight of the system must be included as part of the load weight.

TOWING

All vehicles	On-road	Off-road	Maximum tow hitch load (Nose weight)
Maximum trailer weight:			
Unbraked trailer	750 kg (1 653 lb)	750 kg (1 653 lb)	150 kg (330 lb)
Trailer with over-run brakes	3 500 kg (7 716 lb)	1 000 kg (2 204 lb)	150 kg (330 lb)
Gross Train Weight	6 650 kg (1 4440 lb)	-	150 kg (330 lb)

Note: To increase stability when loading to the maximum trailer weight, it is advised that trailer load distribution is adjusted to achieve the recommended nose weight. See **TOWING, 179**.

Note: Gross Train Weight (with over-run brakes) = GVW plus maximum weight of trailer. Europe only - the GVW used for calculation of GTW includes a legislated extra allowance of 100 kg (220 lb).

Note: For trailers with over-run brakes only, if a greater nose weight is necessary, the recommended 150 kg (330 lb) can be increased up to a maximum of 250 kg (550 lb) total nose weight. However, vehicle payload **MUST BE RESTRICTED** by at least the same weight to ensure that the GVW and rear axle load are not exceeded.

Note: The gross vehicle weight can be increased to a maximum of 3 150 kg (6 945 lb) and the rear axle load can be increased to a maximum of 2 050 kg (4 519 lb) when towing, provided road speed is limited to 100 km/h (60 mph) or 80 km/h (50 mph) when temporary spare wheel is in use.

Dimensions

VEHICLE DIMENSIONS

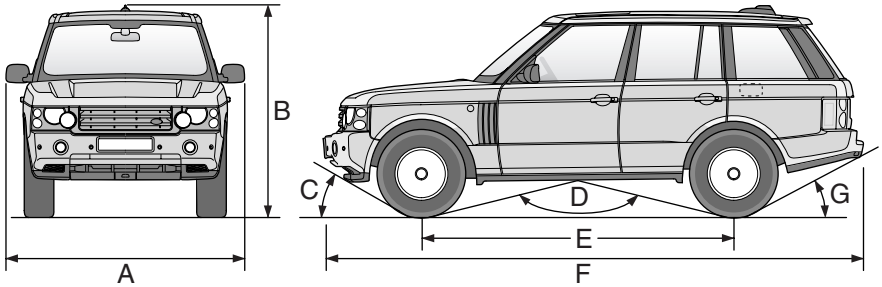

H6517G

A	Overall width	2 191 mm	86.3 in
	Overall width (mirrors folded)	2 009 mm	79.1 in
B	Overall height		
	- Access height	1 820 mm	71.7 in
	- Motorway height	1 840 mm	72.4 in
	- Standard height	1 863 mm	73.3 in
	- Off-road height	1 913 mm	75.3 in
E	Wheelbase	2 880 mm	113.4 in
F	Overall length	4 950 mm	195 in
	Overall length (including tow hitch - to centre of tow ball)	5 015 mm	197.4 in
	Track: - Front	1 629 mm	64.1 in
	Track: - Rear	1 626 mm	64.0 in
	Turning circle	11.6 metres	38 feet

Off road performance

C	Approach angle - Off-road ride height (at EEC kerb weight)	35 degrees	
D	Breakover angle (at EEC kerb weight)		
	- Standard ride height	130 degrees	
	- Off-road ride height	120 degrees	
G	Departure angle without tow hitch (at EEC kerb weight)	29 degrees	
	Departure angle with tow hitch (at EEC kerb weight):		
	- Standard ride height	15.1 degrees	
	- Off-road ride height	17.4 degrees	
	Wading depth	500 mm	20 in
	Minimum ground clearance (off-road height)	281 mm	11.06 in

Dimensions

TOW BAR DIMENSIONS

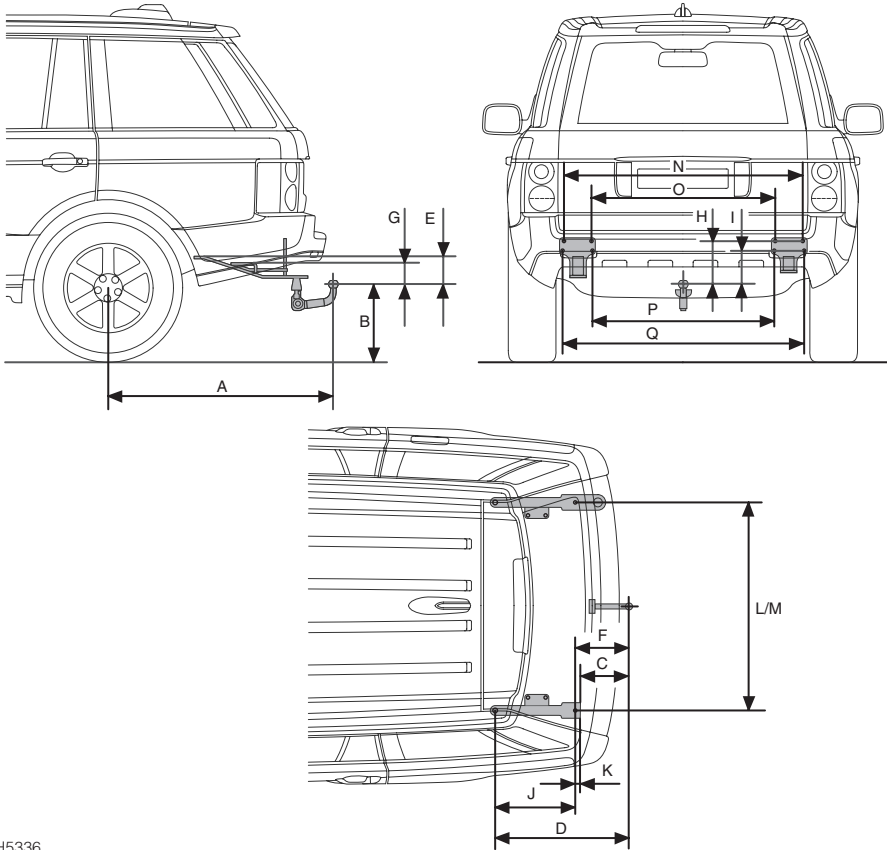

H5336

Note: Dimensions refer to towing equipment officially released by Land Rover.

Dimensions

A	Wheel centre to centre of towball	1 235 mm	48.62 in
B	Ground to centre of towball	397 mm	15.63 in
C	Centre of outer attachment points to centre of towball	252.7 mm	9.95 in
D	Centre of rear inner attachment points to centre of towball (horizontal)	713.5 mm	28.09 in
E	Centre of rear inner attachment points to centre of towball (vertical)	152.7 mm	6.01 in
F	Centre of inner attachments to centre of towball (horizontal)	286 mm	11.26 in
G	Centre of inner attachments to centre of towball (vertical)	138.2 mm	5.44 in
H	Centre of outer No. 1, 2 attachments to centre of towball	236.4 mm	9.31 in
I	Centre of outer No. 3, 4 attachments to centre of towball	184.2 mm	7.25 in
J	Rear inner attachments to inner attachments	427.5 mm	16.83 in
K	Inner attachments to outer attachments	33.3 mm	1.31 in
L	Distance between the rear inner attachments	1 092 mm	42.99 in
M	Distance between the inner attachments	1 092 mm	42.99 in
N	Distance between the outer No. 1 attachments	1 230.6 mm	48.45 in
O	Distance between the outer No. 2 attachments	953.4 mm	37.55 in
P	Distance between the outer No. 3 attachments	940 mm	37.01 in
Q	Distance between the outer No. 4 attachments	1 244 mm	48.98 in

Note: Dimensions refer to towing equipment officially released by Land Rover.

Fuel Consumption

FUEL CONSUMPTION

The fuel consumption figures shown below have been calculated using a standard testing procedure (the new EC test procedure from Directive 99/100/EC), and produced in accordance with The Passenger Car Fuel Consumption (Amendment) Order 1996.

Under normal use, a vehicle's actual fuel consumption figures may differ from those achieved through the test procedure, depending on driving technique, road and traffic conditions, environmental factors, vehicle load and condition.

Fuel consumption figures

	URBAN		EXTRA-URBAN		COMBINED	
	mpg	l/100km	mpg	l/100km	mpg	l/100km
Petrol	13.4	21.2	24.9	11.4	18.9	14.9
Petrol - Supercharged	12.6	22.4	23.1	12.2	17.7	16.0
Diesel	19.6	14.4	30.1	9.4	25.0	11.3

Urban cycle

The urban test cycle is carried out from a cold start and consists of a series of accelerations, decelerations and periods of steady speed driving and engine idling. The maximum speed attained during the test is 50 km/h (30 mph) with an average speed of 19 km/h (12 mph).

Extra-urban cycle

The extra urban test cycle is carried out immediately after the urban test. Approximately half of the test comprises steady-speed driving, while the remainder consists of a series of accelerations, decelerations and engine idling. The maximum test speed is 120 km/h (75 mph) and the average speed 63 km/h (39 mph). The test is carried out over a distance of 7 km (4.3 miles).

Combined

The combined figure is an average of the urban and extra-urban test cycle results, which has been weighted to take account of the different distances covered during the two tests.

Note: *These figures should not be compared with the figures produced using the ECE/EEC procedure previously required by The Passenger Car Fuel Consumption Order 1983. Because of the changes in test procedure, even the urban figures would differ if the same car were subjected to both tests.*